

Check VacStar NEO Model Being Installed:



VS50NEO



VS80NEO

Doctor:	_____
Address:	_____
Phone#:	_____
Dealer:	_____
Dealer Address:	_____

## ***PRODUCT SPECIFICATIONS***

<b>Electrical</b>	<b>Model VS50NEO</b>	<b>Model VS80NEO</b>
Voltage Rating (VAC)	220	220
Voltage Min./Max. (VAC)	198/242	198/242
Frequency Single Phase (Hz)	50/60	50/60
Full Load (Amps)	20	28
<b>Water</b>		
Inlet Water Pressure (PSI)	20 - 100	20 - 100
Flow Rate (gal/min) per Pump	0.13	0.13
Inlet Water Temperature (°F)	40 - 75	40 - 75
<b>Vacuum Level</b>		
Preset at Factory (in Hg)	10	10

All installations must conform to local codes.

# PHYSICAL CHARACTERISTICS

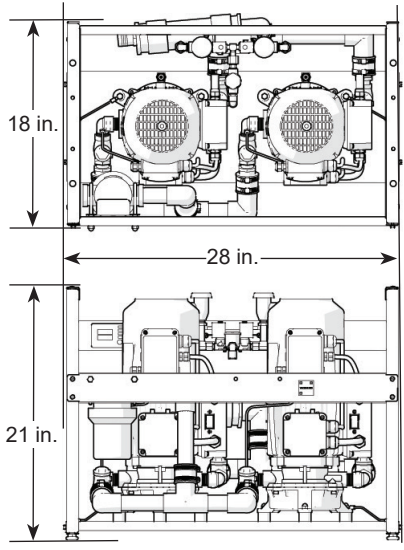
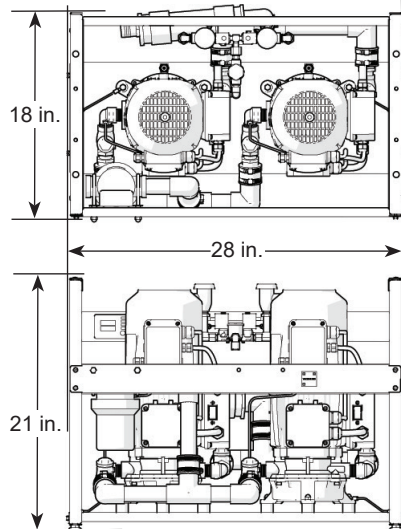
Model VS50NEO		Model VS80NEO	
Height	21 inches (53 cm)	Height	21 inches (53 cm)
Width	28 inches (71 cm)	Width	28 inches (71 cm)
Depth	18 inches (46 cm)	Depth	18 inches (46 cm)
			
<b>Note:</b> Dimensions are +/- 1/2"			
Shipping Weight: 175 lbs. (79 kg)		Shipping Weight: 175 lbs. (79 kg)	

# ELECTRICAL CONNECTIONS

## 220V Connections:

- Each pump has its own 6-foot BX cable pre-wired to the electrical connection box for direct wiring to dedicated 220VAC, single phase 50/60 Hz circuit via a disconnect box with approved ground.
- Disconnect box should be mounted no more than 3 feet of each other and 3 feet of installation center line.
- The supplied cable is pre-wired in the electrical box of each pump. Connect cable wires by matching color.

**Important:** When not connecting a 24VDC remote switch, the ORG and YEL wires must be tied together and the BRN wire insulated for pump operation.

## 24VDC Connections:

- 24VDC Connections are used when installing a 24VDC remote switch. They are made via a supplied interconnect cable that is also pre-wired to the electrical connection box of each pump.
- Make the 24VDC connections shown below for the remote switch. When not using the remote switch, insulate the BRN wire and tie the ORG and YEL wires together.

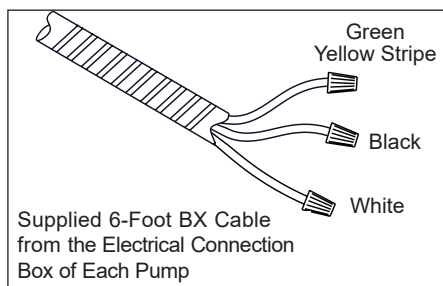

220VAC Connections

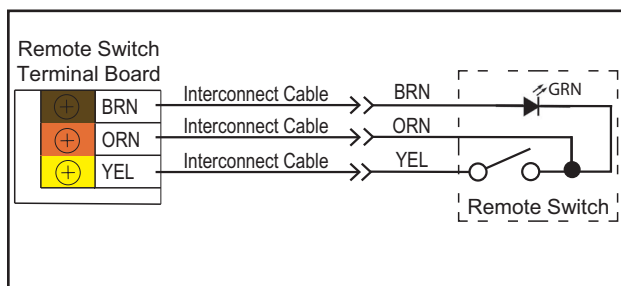

24VDC Connections

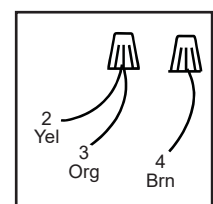

Connection without 24VDC Switch



# UTILITY ROOM CONFIGURATION

## VacStar NEO without Wall-Mounted Air/Water Separator

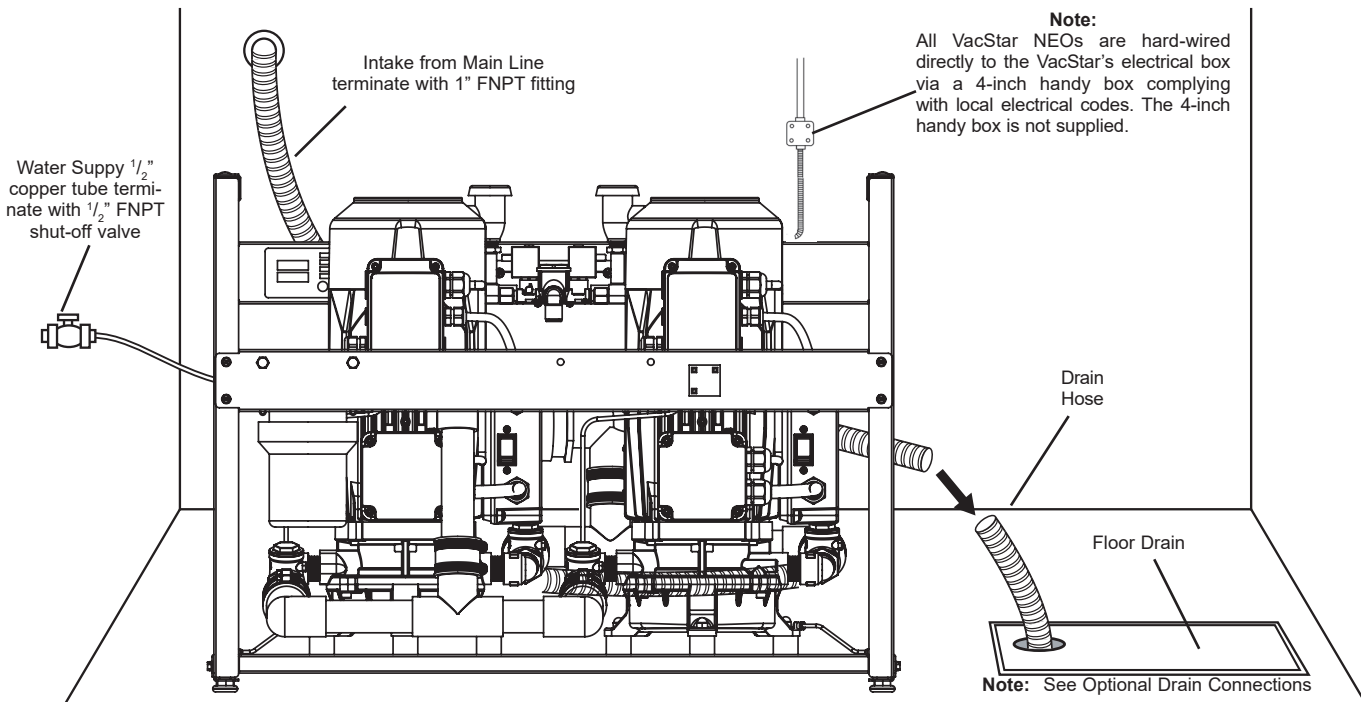

## VacStar NEO with Wall-Mounted Air/Water Separator

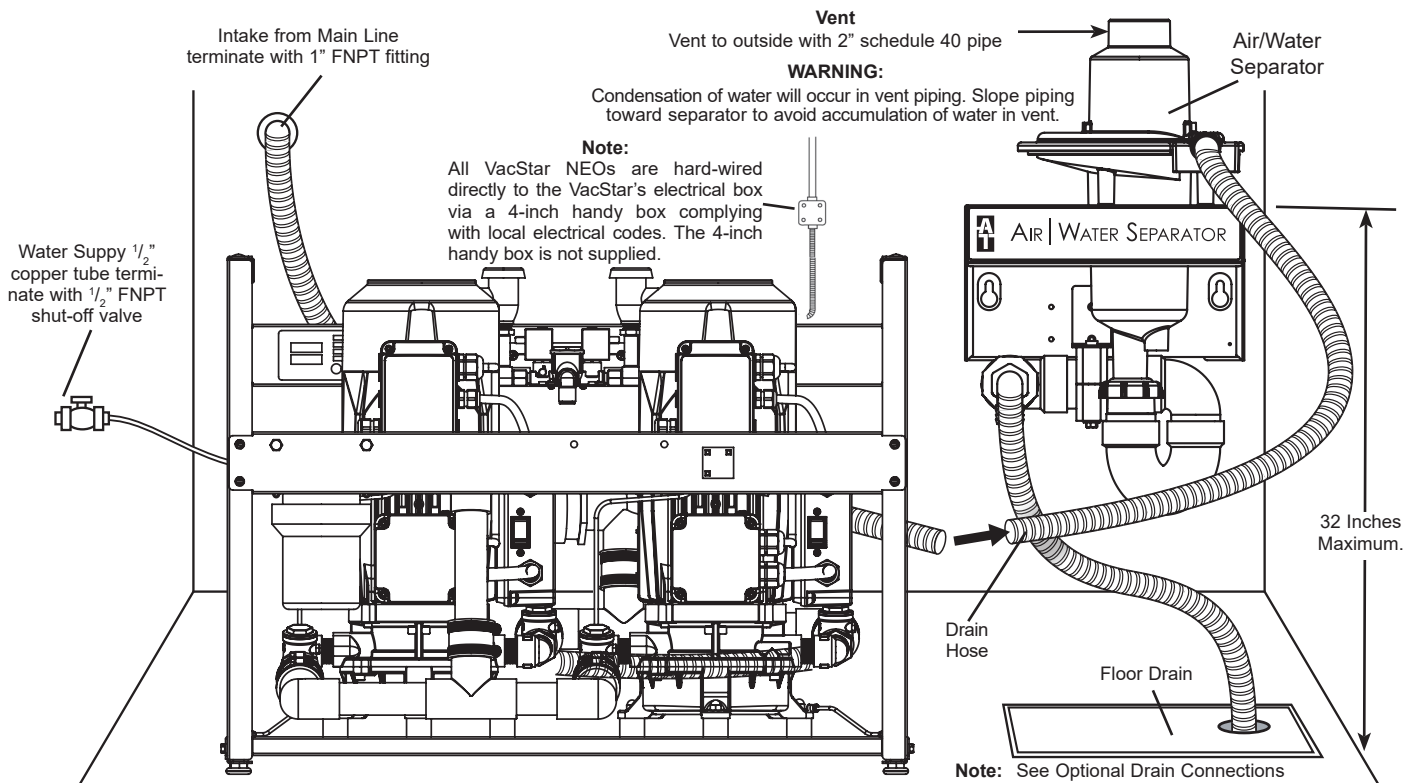

All VacStar NEO vacuums comply with NFPA 99C level 3 requirements

# PLUMBING INSTALLATION

**SUB FLOOR INSTALLATION** - The sub-floor plumbing layout shown below is the **recommended** layout for VacStar system installations and should be used whenever possible.

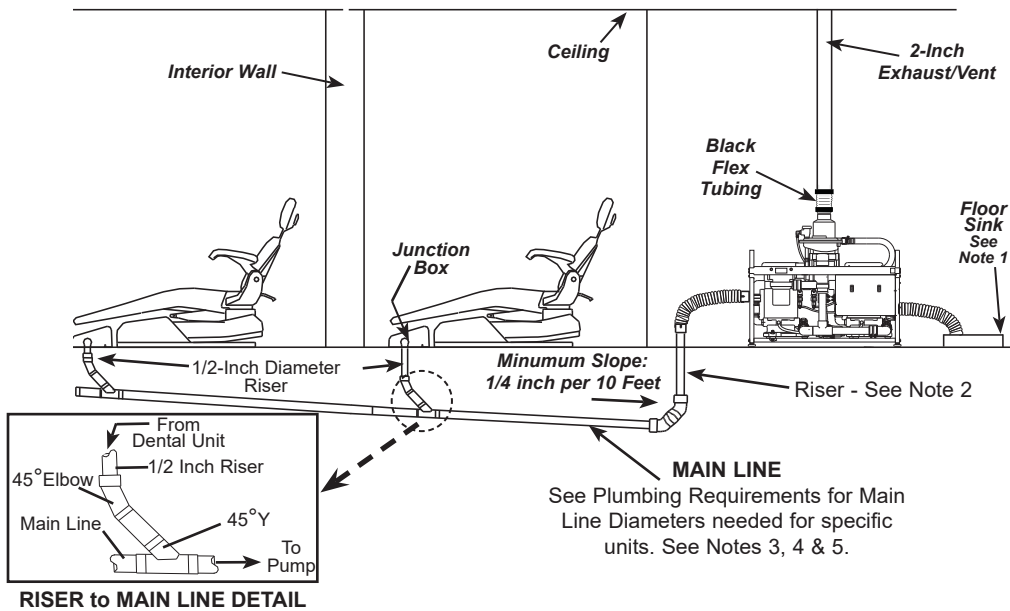

**OVERHEAD INSTALLATION** - The overhead plumbing layout shown below is the alternate layout for VacStar system installations and should be used only when unable to use the sub-floor plumbing layout.

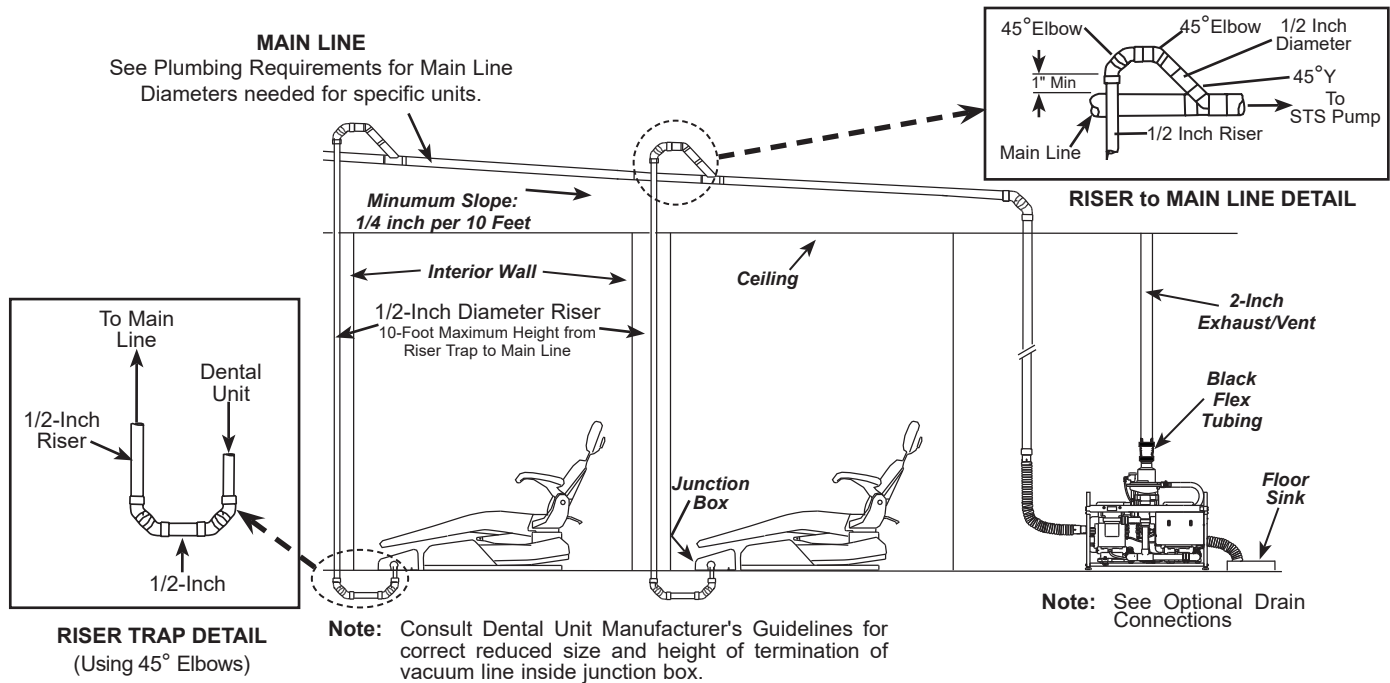

## CONNECTION DETAILS ALL INSTALLATIONS -

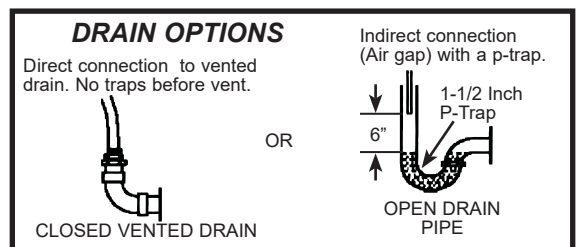
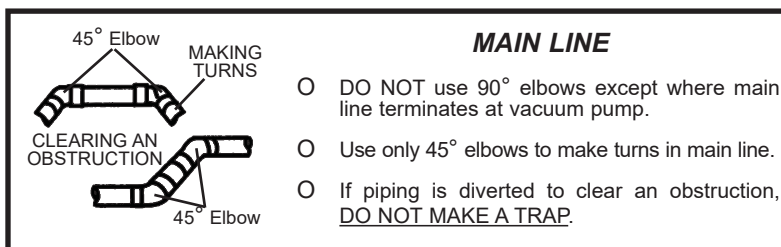

All installations must conform to local codes.

# SITE REQUIREMENTS

<b>Electrical</b>	<b>VS50NEO</b>		<b>VS80NEO</b>	
Connection Option	Two 15A Services	Single 30A Service	Two 20A Services	Single 40A Service
Minimum Circuit Breaker Rating	15A, Qty 2	30A, Qty 1	20A, Qty 2	40A, Qty 1
Minimum Wire Gauge Size	14 AWG, Qty 2	10 AWG, Qty 1	12 AWG, Qty 2	8 AWG, Qty 1
220-Volt Buck/Boost Transformer	#67002 (3.9 KVA), Qty 2	#67000-1 (7.8 KVA), Qty 1	#67002 (3.9 KVA), Qty 2	#67000-1 (7.8 KVA), Qty 1
<b>Plumbing</b>				
<b>Note:</b> Suction piping must slope at least a ¼" for each 10 feet of run towards the pump. Use PVC Schedule 40 or Copper Type M.				
Minimum CFM @ 0" Hg	30		40	
Air Exhaust with Air/Water Separator	2" schedule 40 pipe		2" schedule 40 pipe	
<b>Overhead Plumbing</b>				
Main Line Diameter (Min./Max. ID in inches)	1 ¼" to 2"		1 ½" to 2"	
End Fitting	¾" FNPT		¾" FNPT	
Overhead Main Line	½" ID		½" ID	
<b>Floor Plumbing</b>				
Main Line Diameter (Min./Max. ID in inches)	1 ¼" to 2"		1 ½" to 2"	
End Fitting	¾" FNPT		¾" FNPT	
Branch Line Diameter (Min./Max. ID in inches)	¾" to 1 ½"		1 to 1 ½"	
<b>Environmental</b>				
Ambient Temperature (See ventilation requirements below.)	40 to 104°F (5 to 40°C)		40 to 104°F (5 to 40°C)	

# VENTILATION REQUIREMENTS

## Equipment Room Temperature

The VacStar NEO equipment must be used in a controlled temperature environment. Maintain equipment room temperature between 40 and 105 degrees Fahrenheit. Adequate forced ventilation must be provided across the unit by placing an appropriate exhaust fan opposite an equivalent air intake vent. The fan should be higher than the associated intake vent.

## Exhaust Vent Protection.

If the exhaust piping is venting to the outside of the building, precautions must be taken to protect the equipment room from weather elements and animal intrusion. This can be accomplished by using one of the three methods shown below.

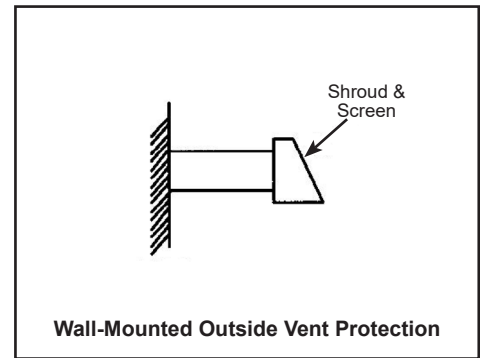
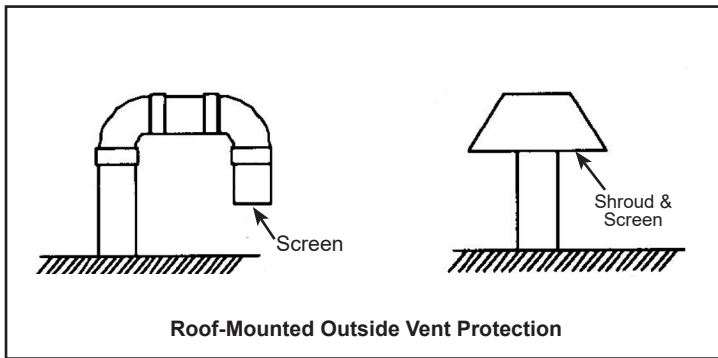

Unit	Watts (Idle)	Watts (Max)	BTU/Hr (Idle)	BTU/Hr (Max)
VS50NEO	1,451	2,732	2,346	4,112
VS80NEO	1,451	4,099	2,346	8,774

Make sure to use the required pipe type for associated system



For over 50 years, Air Techniques has been a leading innovator and manufacturer of dental products. Our priority is ensuring complete satisfaction by manufacturing reliable products and providing excellent customer and technical support. Whether the need is digital imaging, utility room equipment or merchandise, Air Techniques can provide the solution via our network of authorized professional dealers. Proudly designed, tested and manufactured in the U.S., our products are helping dental professionals take their practices to the next level.

Air Techniques' family of quality products for the dental professional include:

- ❑ **Digital Imaging**
  - Digital Radiography
  - Intraoral Camera
  - Caries Detection Aid
  - Intraoral X-ray
  - Panoramic X-ray
  - Film Processors
  
- ❑ **Utility Room**
  - Dry Vacuums
  - Wet Vacuums
  - Air Compressors
  - Amalgam Separator
  - Utility Accessories
  - Utility Packages
  
- ❑ **Merchandise**
  - Surface Disinfectant
  - Enzymatic Cleaner
  - Hand Sanitizer and Lotion
  - Waterline Cleaner
  - Evacuation System Cleaner
  - Imaging Accessories
  - Chemistry
  - Processor Accessories

**Corporate Headquarters**

1295 Walt Whitman Road | Melville, New York 11747- 3062  
Phone: 800-247-8324 | Fax: 888-247-8481

[www.airtechniques.com](http://www.airtechniques.com)

